



This document provides all the necessary information to allow your new product to be properly and safely installed. Before beginning the installation and/or operation of your new product, the installation technician and operator must read the manual completely. Important information is contained herein and could prevent serious injury and damage.

Proper installation of this product requires the installer to have a good understanding of automotive electronics, systems and procedures. Do not install this product or route any wires in the deployment area of your airbag.

Equipment mounted or located in the airbag deployment area will damage or reduce the effectiveness of the airbag, or become a projectile that could cause serious personal injury or death. Refer to your vehicle owner manual for the airbag deployment area. The User/Installer assumes all responsibility to determine proper mounting location, based on providing ultimate safety to all passengers inside the vehicle.

If this product uses a remote device to activate or control this product, make sure that the control is located in an area that allows both vehicle and the control to operate safely in all driving conditions. If mounting this product requires drilling holes, the installer must be sure that no vehicle components or other vital parts can be damaged by the drilling process. Check both sides of the mounting surface before drilling begins. Also de-burr any holes and remove any metal shards or remnants. Install grommets into all wire passage holes. Do not attempt to activate or control this device in a hazardous driving situation.

Use only soap and water to clean the outer lens. Use of other chemicals could result in premature lens cracking (crazing) and discoloration. Lenses in this condition have significantly reduced effectiveness and should be replaced immediately. Inspect and operate this product regularly to confirm its proper operation and mounting condition. Do not use a pressure washer to clean this product. For this product to operate at optimum efficiency, a good electrical connection to chassis ground must be made. The recommended procedure requires the product ground wire to be connected directly to the Negative (-) battery post.

It is recommended that these instructions to be stored in a safe place and referred to when performing maintenance and/or reinstallation of this product.

**FAILURE TO FOLLOW THESE SAFETY PRECAUTIONS AND INSTRUCTIONS COULD RESULT IN DAMAGE TO THE PRODUCT OR VEHICLE AND/OR SERIOUS INJURY TO YOU AND YOUR PASSENGERS!**



## Wiring Instructions-Handheld Controller(Provided)

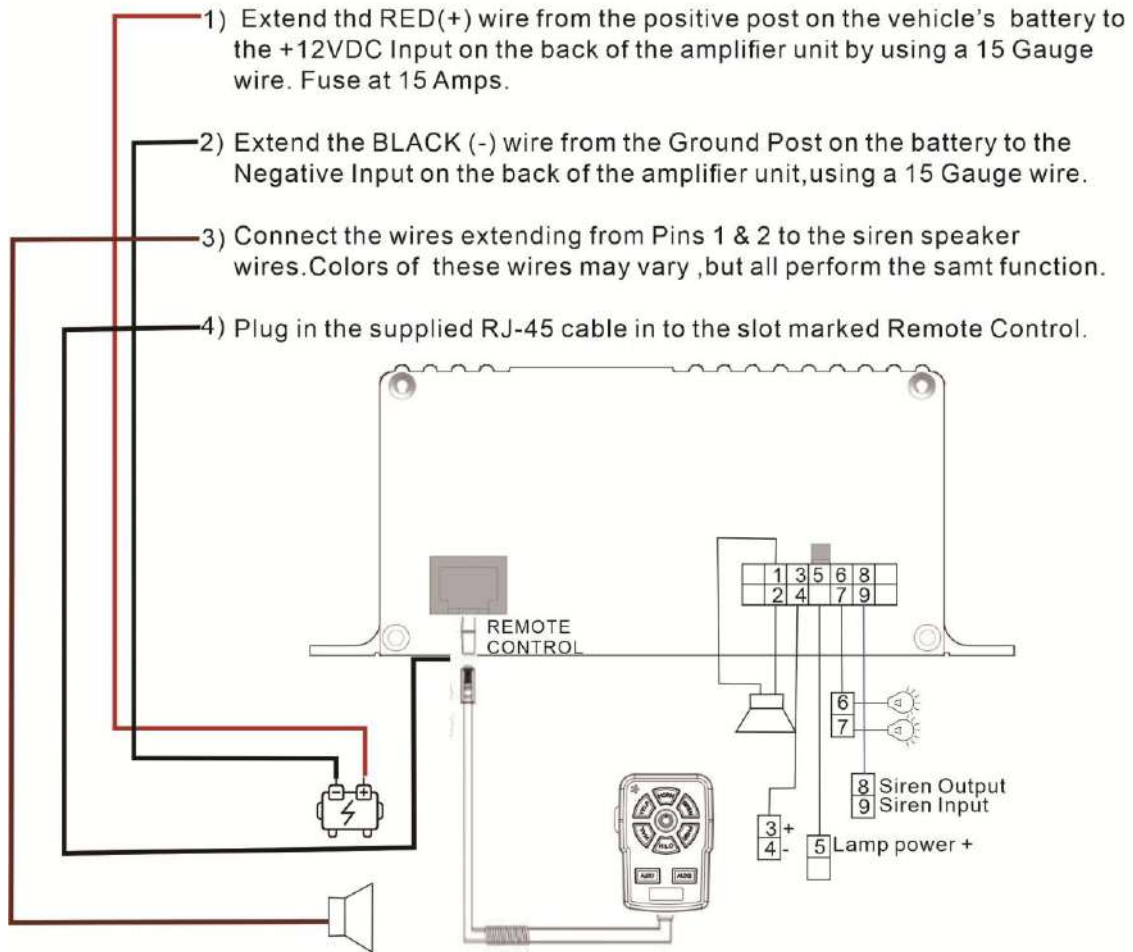

### To attach accessories to Outputs 1 & 2:

A) Connect the accessory's ground wire to ground post from battery.

B) Attach the **POSITIVE(+)** wire to either Output 1 or Output 2. Be sure to fuse appropriately

### ◆ Wiring Instruction

Brown wire ---Speaker

Brown wire ---Speaker

Thick Red wire---Amp Power+

Black wire ---Amp Ground

Thin Red wire---Light Power+

White wire ---Light 1

Green wire --Light 2

Top Blue wire---Siren Output

Bottom Blue wire ---Siren Input